

PLASTIC SNAP TOGETHER D HOOD + HIGH DENSITY SOLDER FEMALE

TECHNICAL SPECIFICATIONS

D-SUB HOOD, PLASTIC SNAP TOGETHER, BLACK

Material:	Nylon UL94 V-2
Temperature range:	-55°C to 105°C
Cable strain relief:	Cable clamp with self-tapping screws
Cable diameter:	3.0 - 11.0 mm
Locking screws:	Long jackscrews with moulded top for colour coding
Cable outlet:	Straight

FEMALE HIGH DENSITY CONNECTOR SOLDER CUP, STAMPED

Insulator:	Glass filled Polyester, Black UL94 V-0
Shell:	Stamped Steel, Tin Plated
Contact pins:	Copper Alloy
Machined pins:	100 inserts min.
Contact plating:	Selective Gold over Nickel
Contact current rating:	2 Amps max
Contact resistance:	25mΩ max
Operating temperature:	-55°C to +105°C
Withstanding voltage:	500V AC for 1 minute
Insulator resistance:	500MΩ min (At 500V DC)

FEMALE HIGH DENSITY CONNECTOR SOLDER CUP, MACHINED

Insulator:	Glass filled Polyester, Black UL94 V-0
Shell:	Stamped Steel, Tin Plated
Contact pins:	Copper Alloy
Machined pins:	500 inserts min.
Contact plating:	Selective Gold over Nickel
Contact current rating:	5 Amps max
Contact resistance:	25mΩ max
Operating temperature:	-55°C to +105°C
Withstanding voltage:	1000V AC for 1 minute
Insulator resistance:	1000MΩ min (At 500V DC)

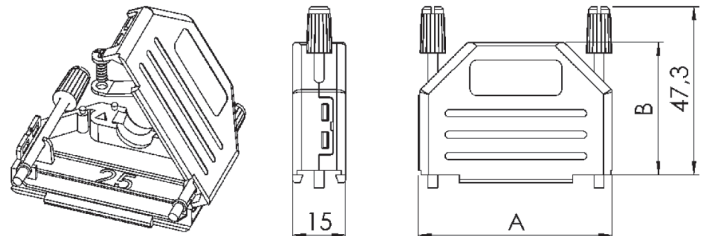
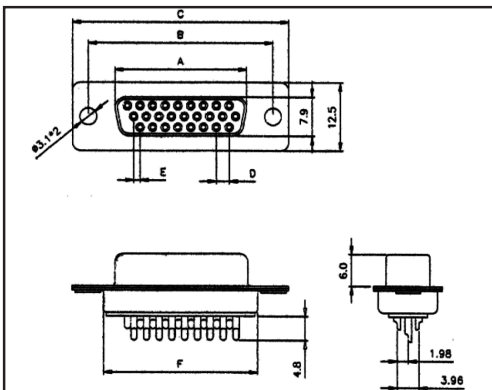

Size	A	B	C	D	E	F
HD15	16,30	25,00	30,8	2,29	1,14	19,2
HD26	24,60	33,30	39,2	2,29	1,14	27,7
HD44	38,30	47,10	53,1	2,29	1,14	41,1
HD62	54,80	63,50	69,4	2,41	1,20	57,3
HD78	52,20	61,00	67,0	2,41		55,1

Size	Dim A	Dim B	Dim C
9-way	32,4	31,3	15,0
15-way	40,7	30,8	15,0
25-way	54,4	37,3	15,0
37-way	70,9	36,0	15,0
50-way	67,5	40,0	15,0

HOOD + STAMPED ECONOMY CONTACT CONNECTOR

Size	Product Code
9-way	DPPK09-BK-HDB15S-K
15-way	DPPK15-BK-HDB26S-K
25-way	DPPK25-BK-HDB44S-K
37-way	DPPK37-BK-HDB62S-K
50-way	DPPK50-BK-HDB78S-K

HOOD + MACHINED HIGH QUALITY CONTACT CONNECTOR

Size	Product Code
9-way	DPPK09-BK-HDM15S-K
15-way	DPPK15-BK-HDM26S-K
25-way	DPPK25-BK-HDM44S-K
37-way	DPPK37-BK-HDM62S-K
50-way	DPPK50-BK-HDM50S-K