

R&H Filter Fan LV200

Filterlüfter
Filter Fan

LV 200



Technische Daten / Technical data:

Type:	LV 200			
Spannung Voltage	230 V 50/60 Hz	115 V 50/60 Hz	24 V DC	
Stromaufnahme Amperage	0,11 A	0,23 A	0,17 A	
Leistung Power input	20 W		4,1 W	
Drehzahl Speed	2650/3100 min ⁻¹		3050 min ⁻¹	
Temperaturbereich Temperature range	-10...+55°C		-20...+65°C	
Lebensdauer Service life	27.500 h		50.000 h	
Schallpegel Noise level	42 dB (A)		42 dB (A)	
Zulassung Approval	UL, CE			
Farben colours	RAL 7035 (Standard), RAL 7032			
Schutzart Degree of protection	IP 54			
Luftfördermenge / Air flow: (m ³ /h)				
Filtermatte Filter mat	P15/350S 50 Hz	P15/350S 60Hz	P15/500S 50Hz	P15/500S 60Hz
Luftleistung freiblasend Air flow free air	58	65	46	52
mit Austrittsfilter GV 200 with exhaust filter	40	43	30	32

Zubehör / Accessories:

Austrittsfilter / Exhaust filter

Dichtung / gasket (enthalten / included)

Ersatzfiltermatte / Replacement filter mat

Thermostate / Thermostats

GV 200

D 200

AM 235P, AM 200P

TRS 60, TRW 60, TWR 60, TKW 60

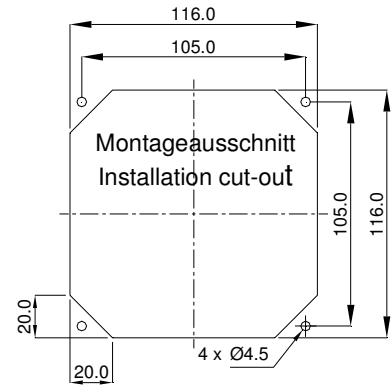
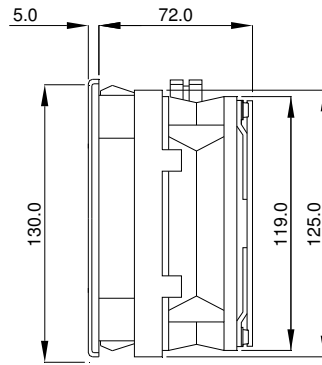
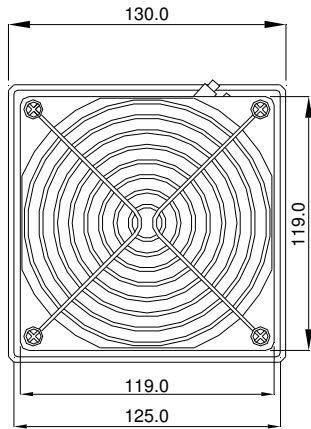

Achteckiger Ausschnitt und Bohrungen
nur bei Schraubbefestigung

Octagonal cut-out and
drill-holes are only necessary for
screw-fastening

Leistungsdiagramm
Performance diagram

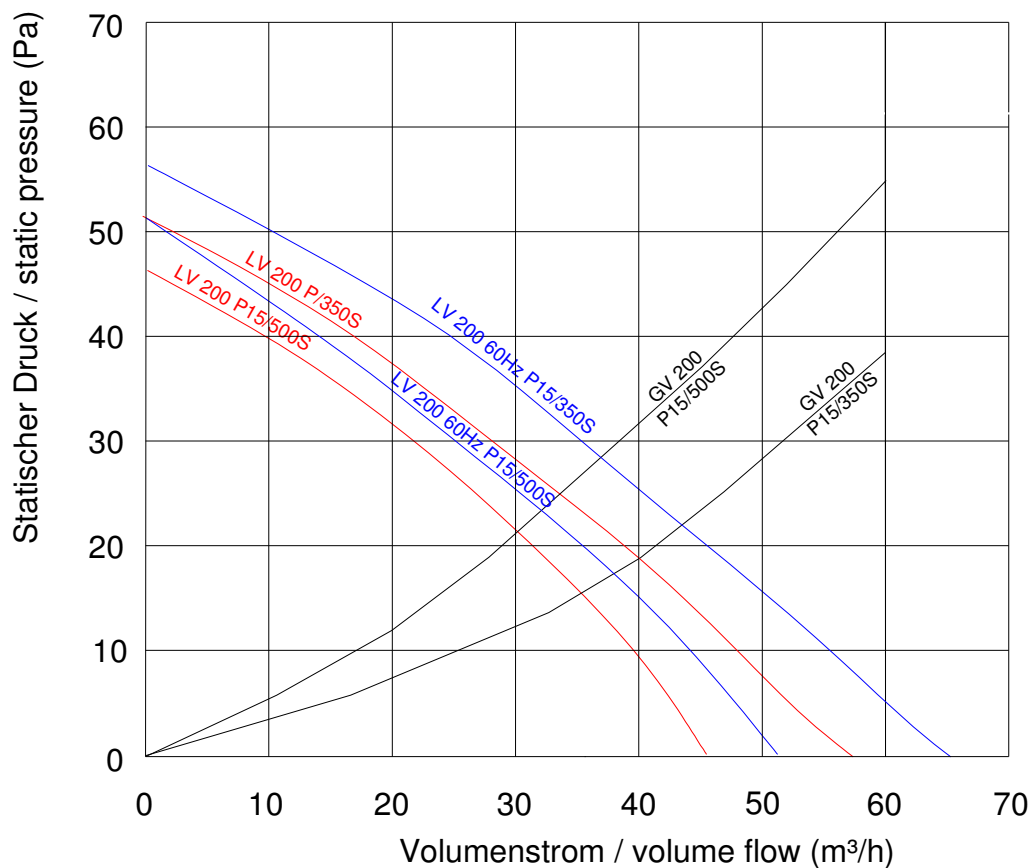

Rev.03/11